

JIMG[®]



MC100.08

metric

Max Capacity:
15.000 kg

MC100.08



Configurable

The quick change boom feature allows the same crane to perform very different tasks.



Compact

Compact size for making precise maneuvers in tight spaces.



Adaptable

This **MC100.08** offers unparalleled versatility with the expanding wheelbase and the quick boom change, designed to adapt to any request.



Optionals

01

Hydraulic winch

02

Hydraulic jib

03

Mechanic jib

04

Hydraulic fork

05

Custom color



Directives. Regulations.



UNI ISO

4301-1:A1



UE / CE

2006/42 CE

2014/30 UE

2014/35 UE

2000/14

and any subsequent changes.



OTHER

EN 13000:2014

ANSI/ASME B30.5-2011

EN 12999:2020

and any subsequent changes.

Technical Details.

Maximum capacity

At hook

15.000 kg

Total weight

short boom

15.400 kg

Counterweights

removable

1.600 kg Z1

1.400 kg Z2

Traction motor

Front axle
2x 7.5Kw AC

Battery

lithium

working time up to 8 hours
80V 608Ah

Pump

35Kw AC
variable cc pump

Boom angle

from -5° to 70° boom

LMI

Load indicator and overturning
moment limiter

Brakes

automatic electro-mechanical
braking system
stop on ramp +

Short boom

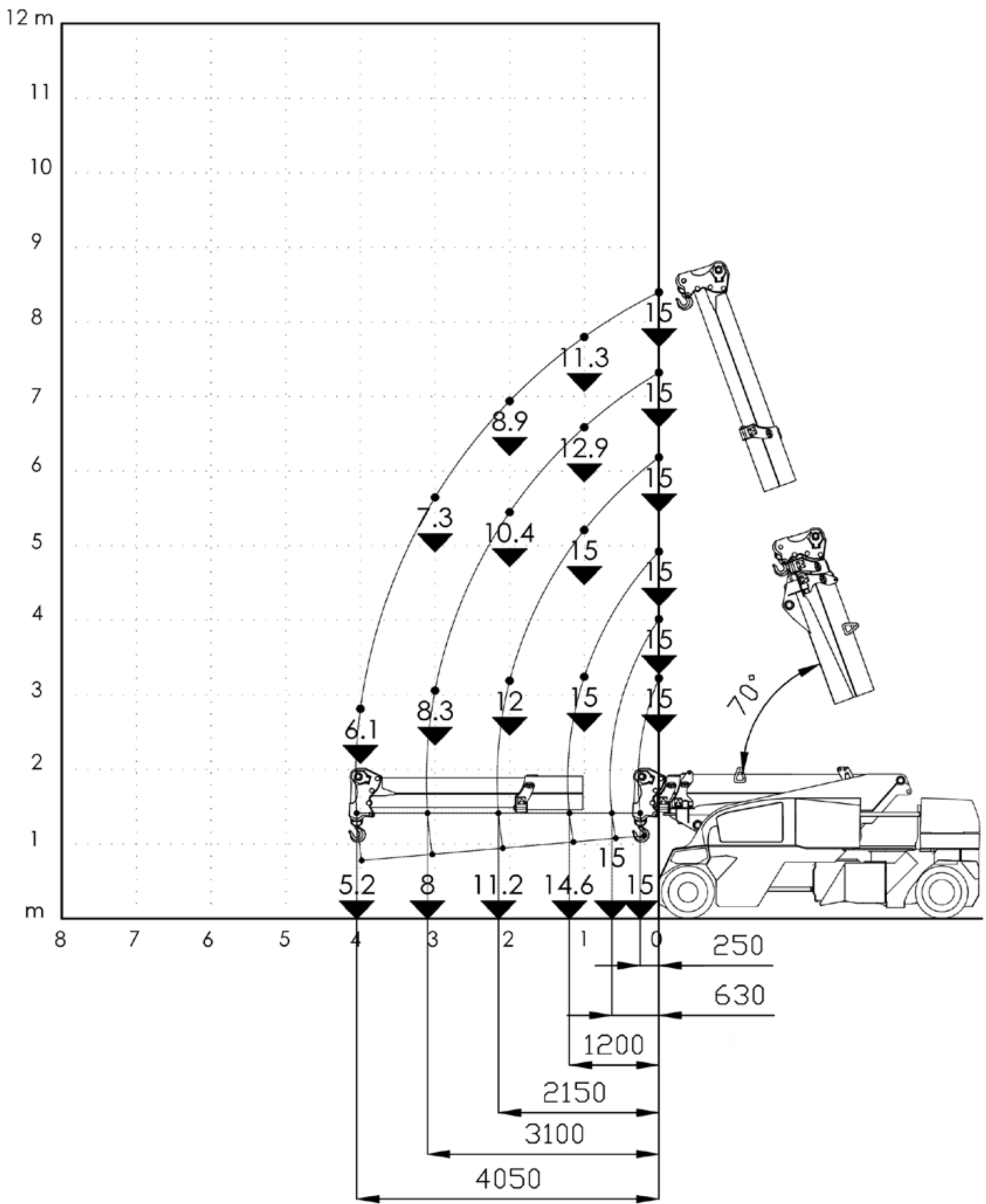

Single hook

15.000 kg

Double hook

15.000 kg

Winch

15.000 kg - 8°

+

Fork

10.000 kg - 0.8 m

Hydraulic jib

6.000 kg - 2.4 m

Mechanic jib

7.500 kg - 0.75 m

Long boom

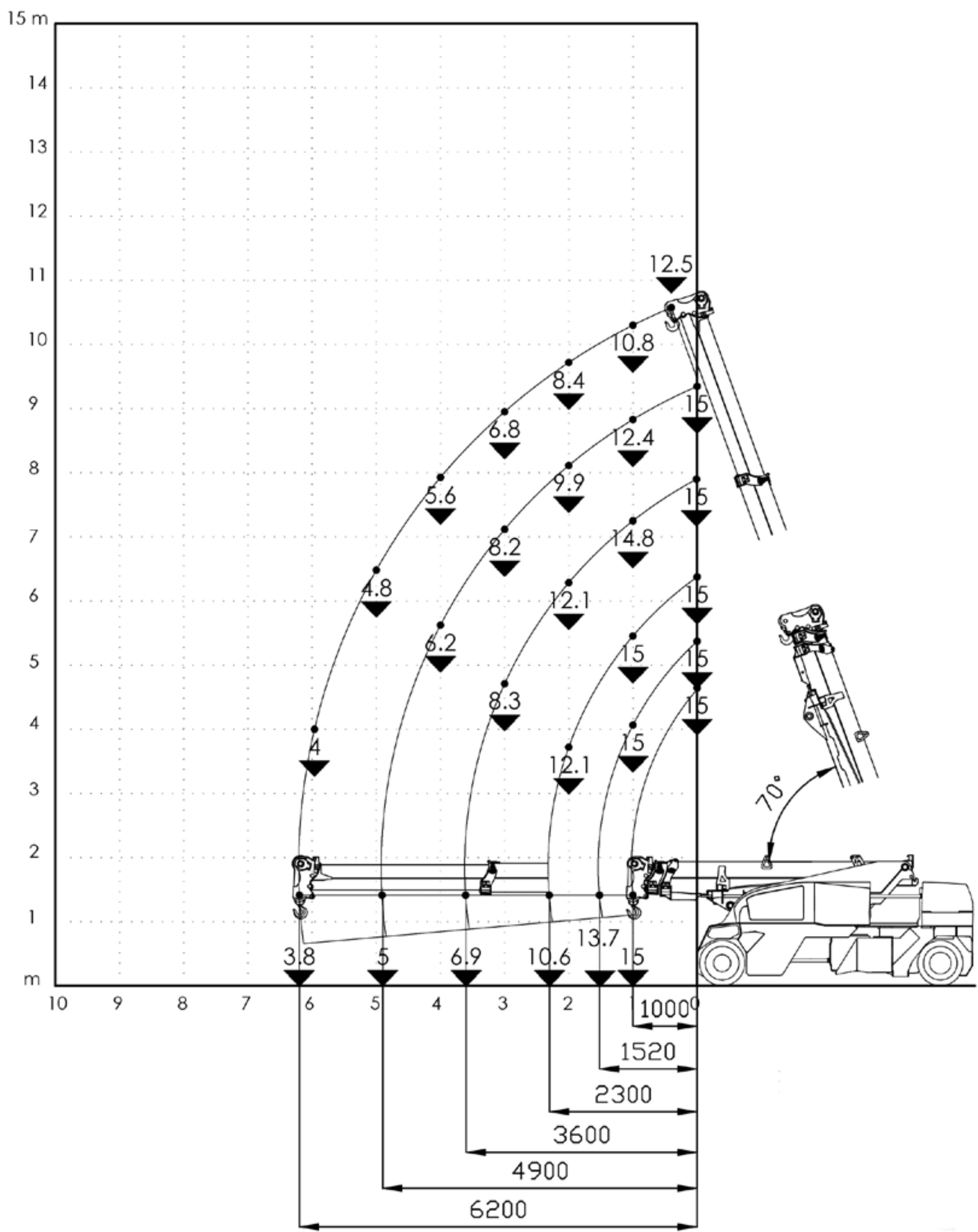

Single hook

15.000 kg

Double hook

15.000 kg

Winch

15.000 kg - 8°

+

Fork

10.000 kg - 0.8 m

Hydraulic jib

6.000 kg - 2.4 m

Mechanic jib

7.500 kg - 0.75 m

Single element

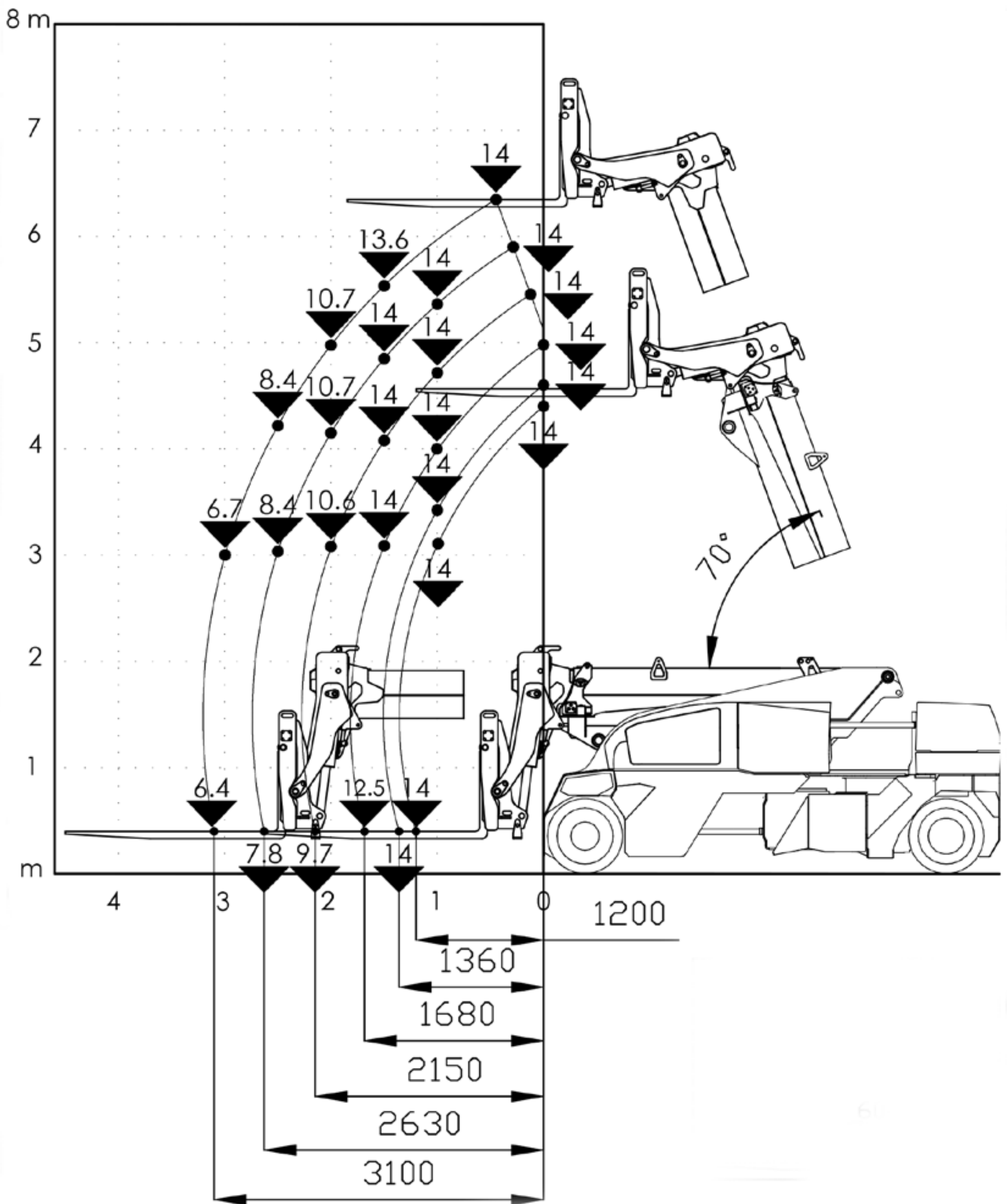

Single hook

15.000 kg

Double hook

15.000 kg

Fork

14.000 kg - 0.6 m



The single-element boom allows for the full utilization of the 14,000kg fork capacity within the range highlighted in the table.

Dimensions

MC100.08



3490mm - 1600mm - 2034mm

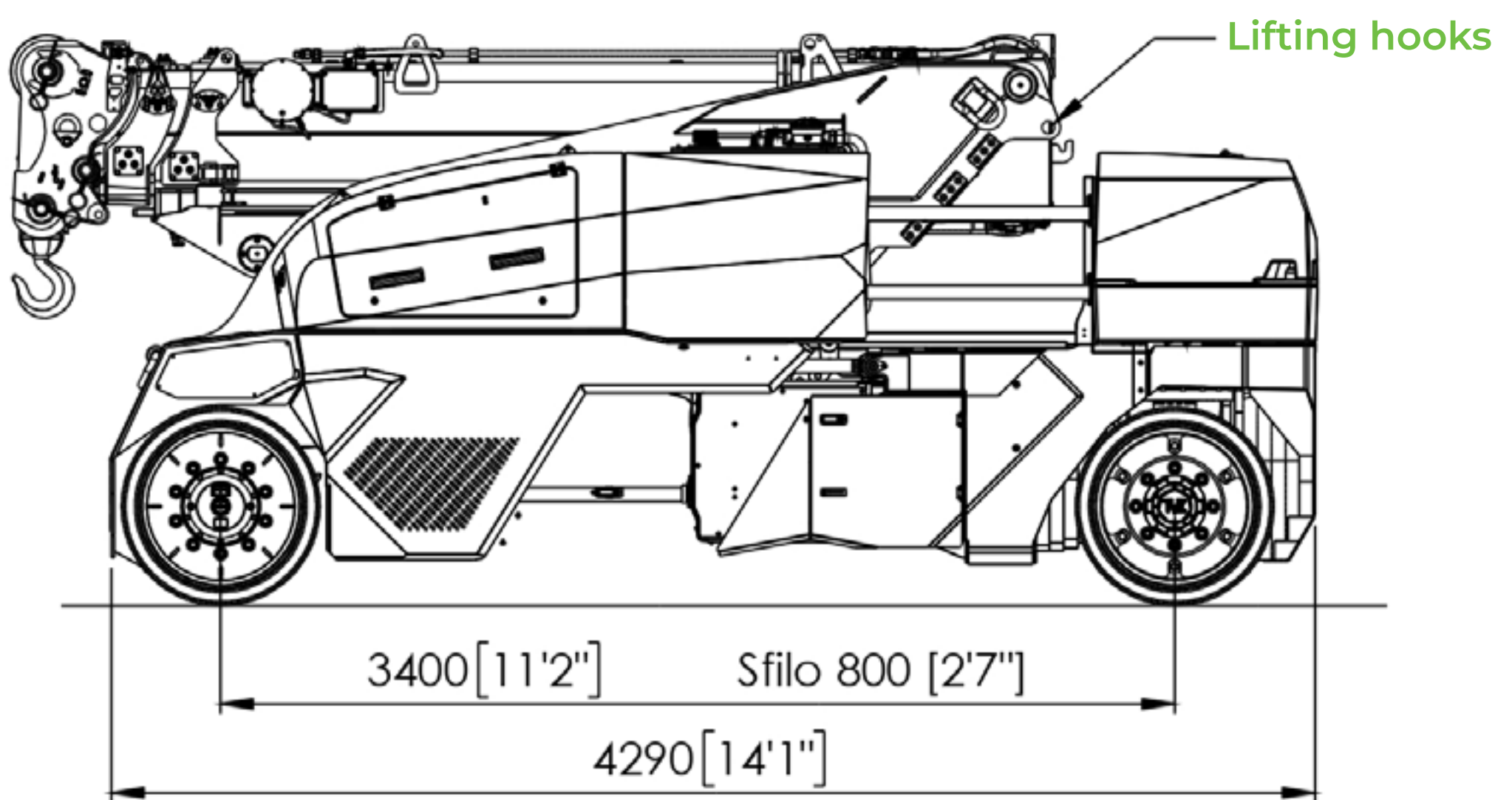
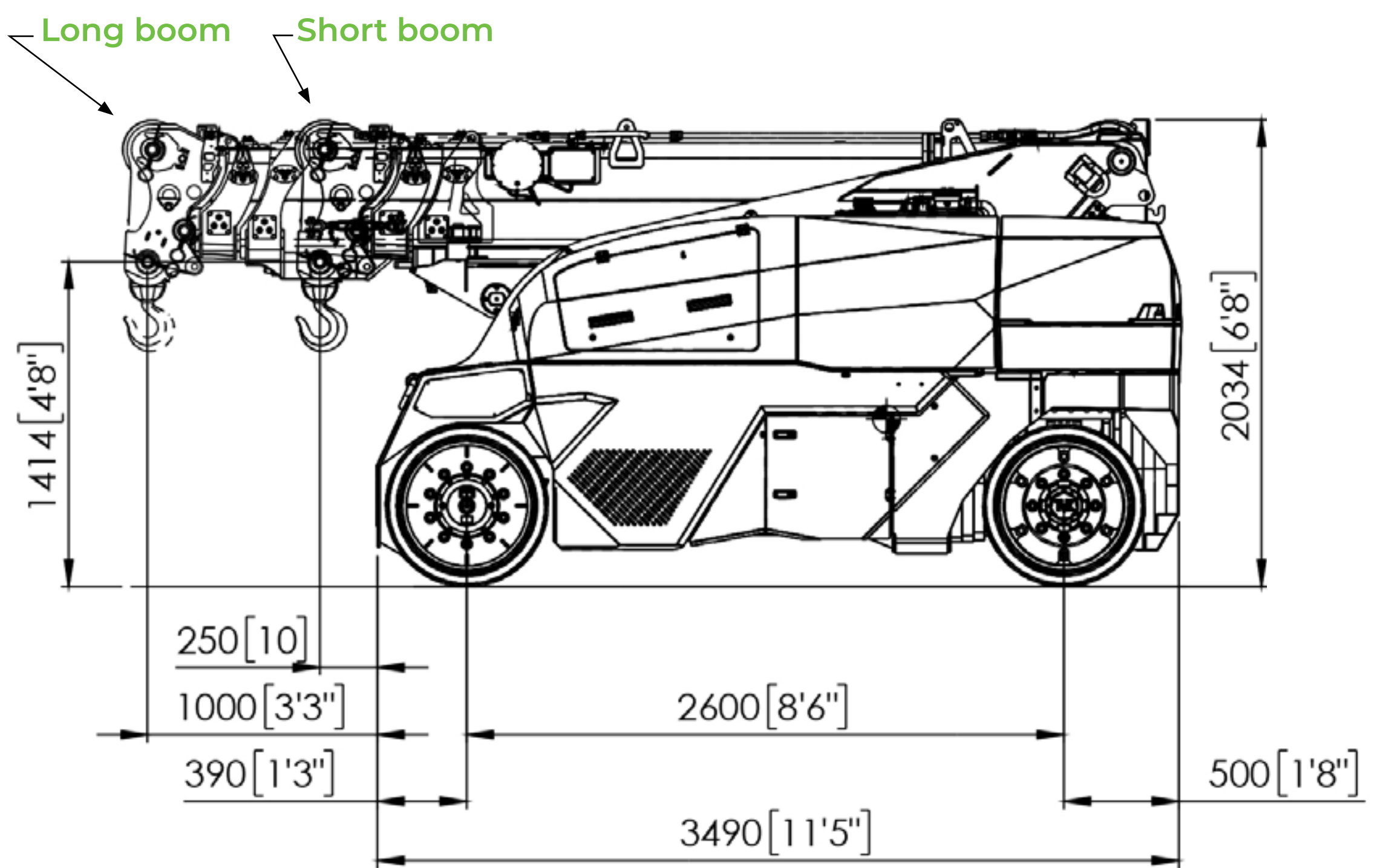
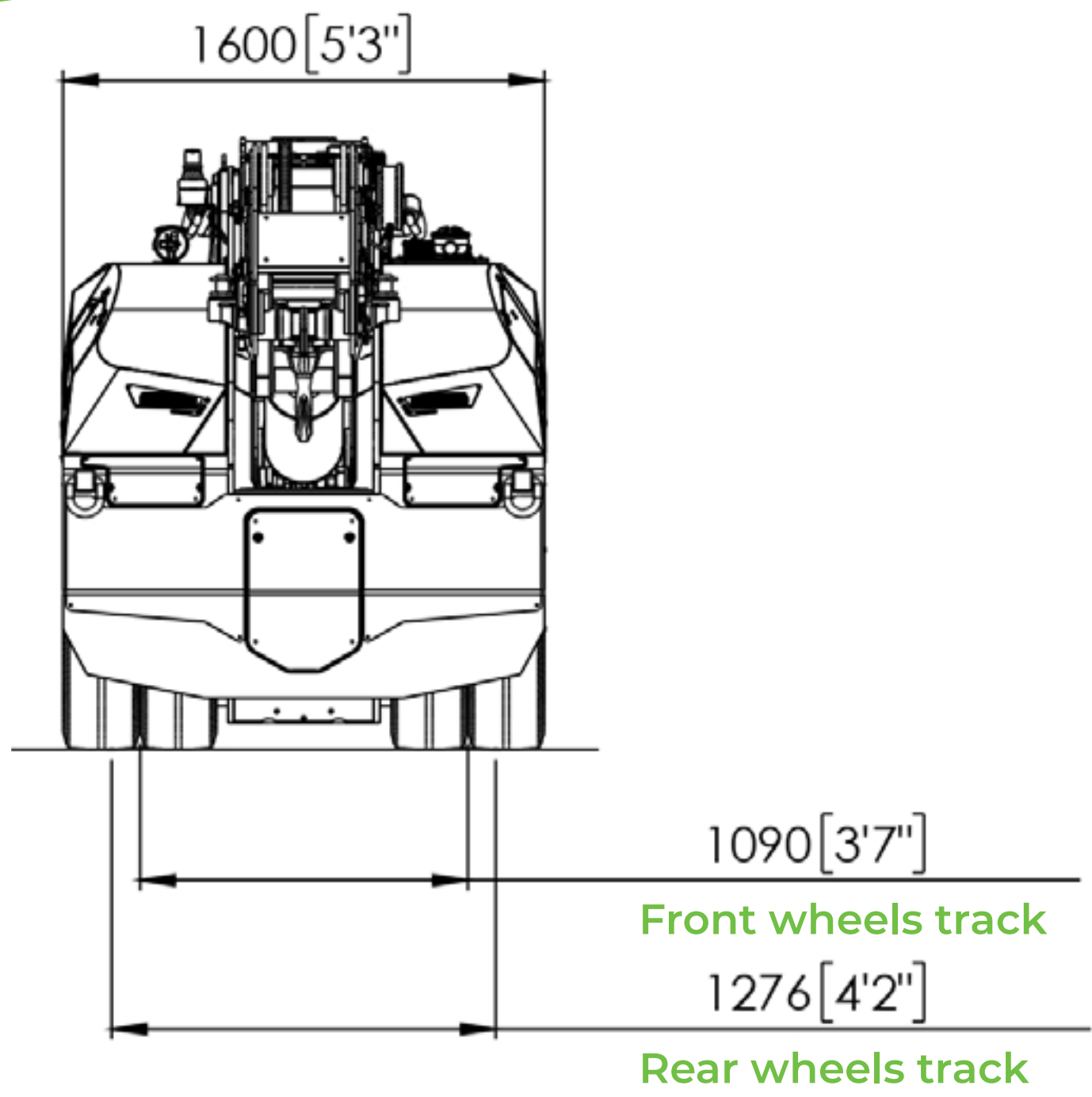

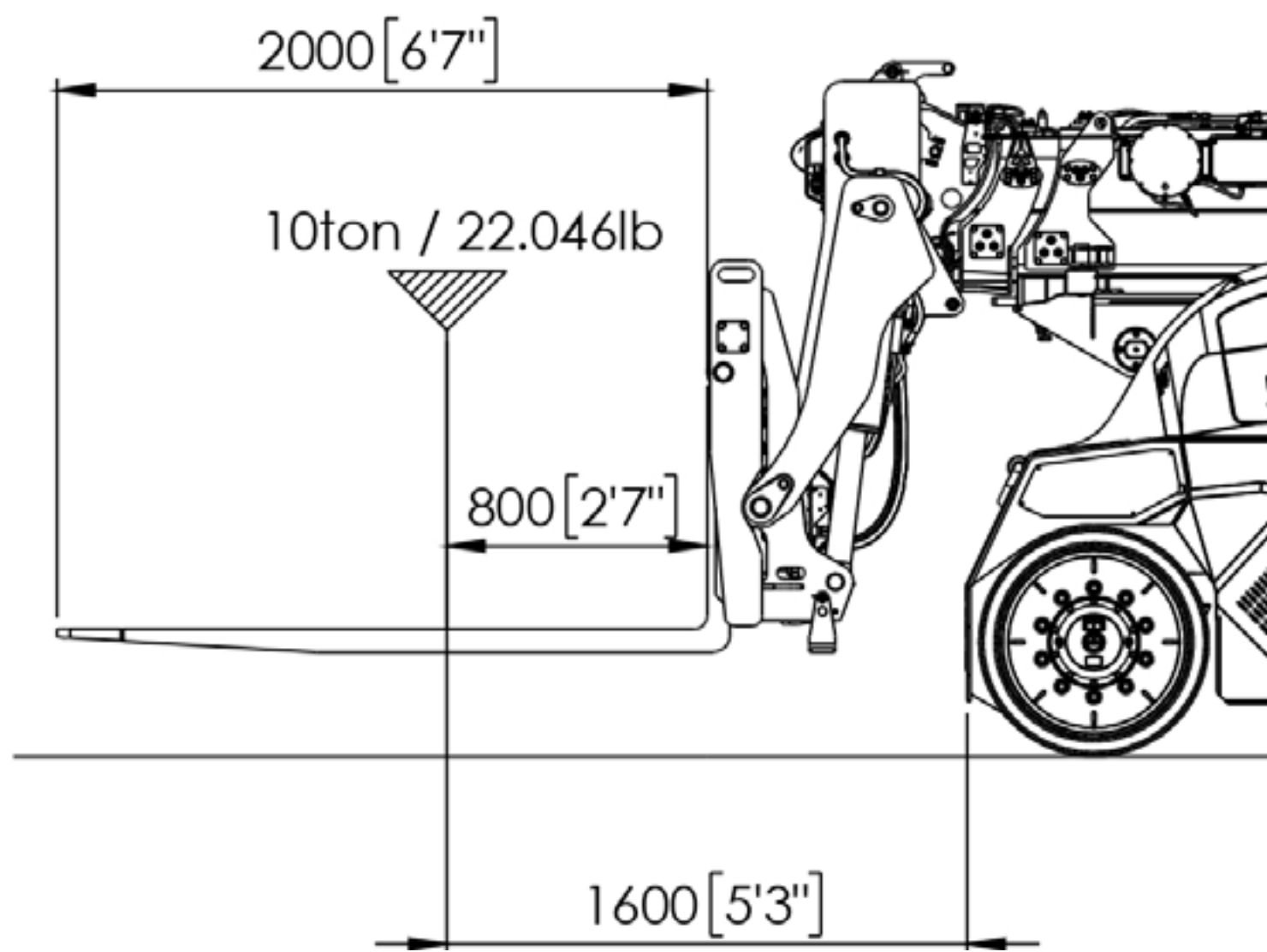

Fork on short boom

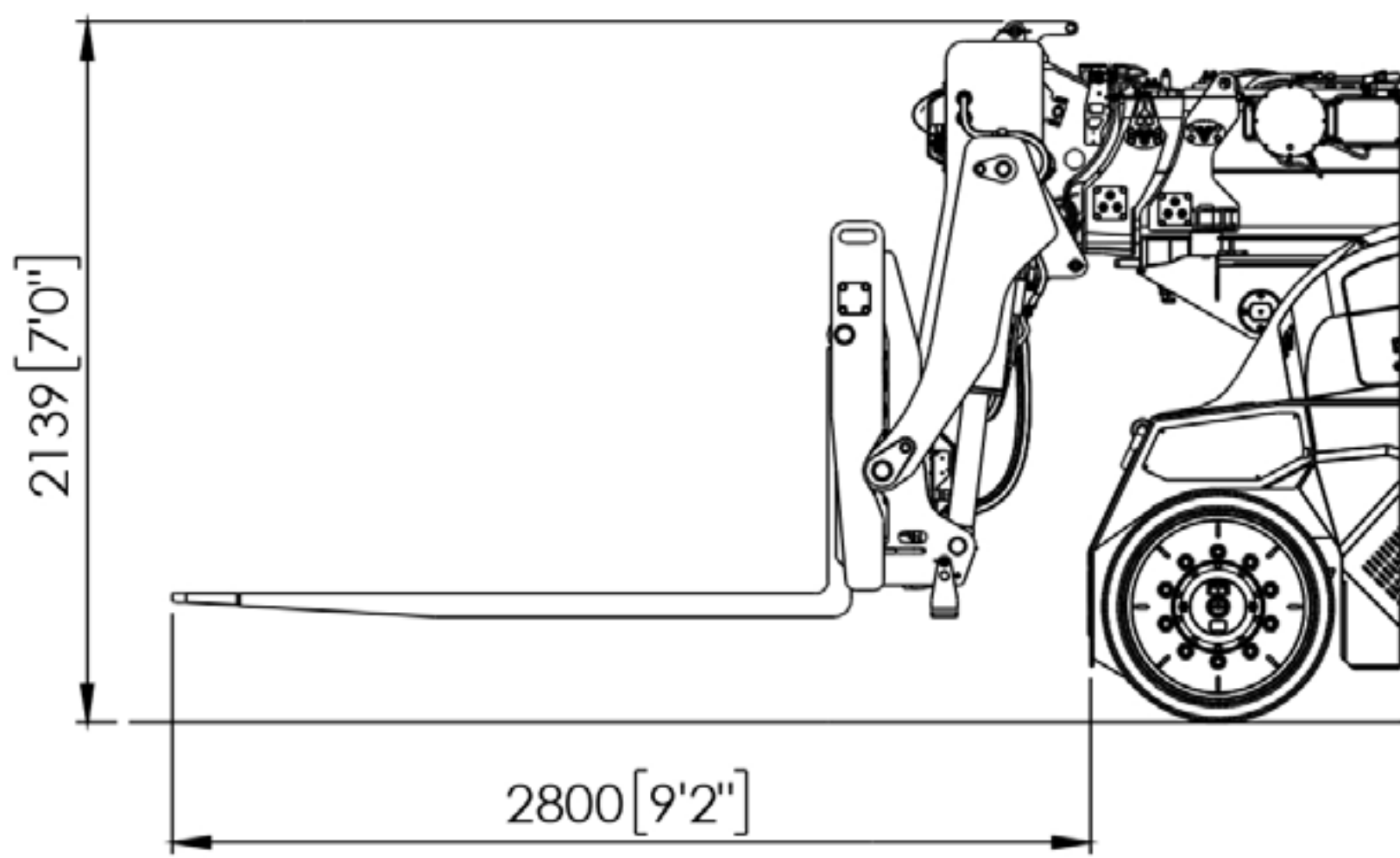

Fork on short boom

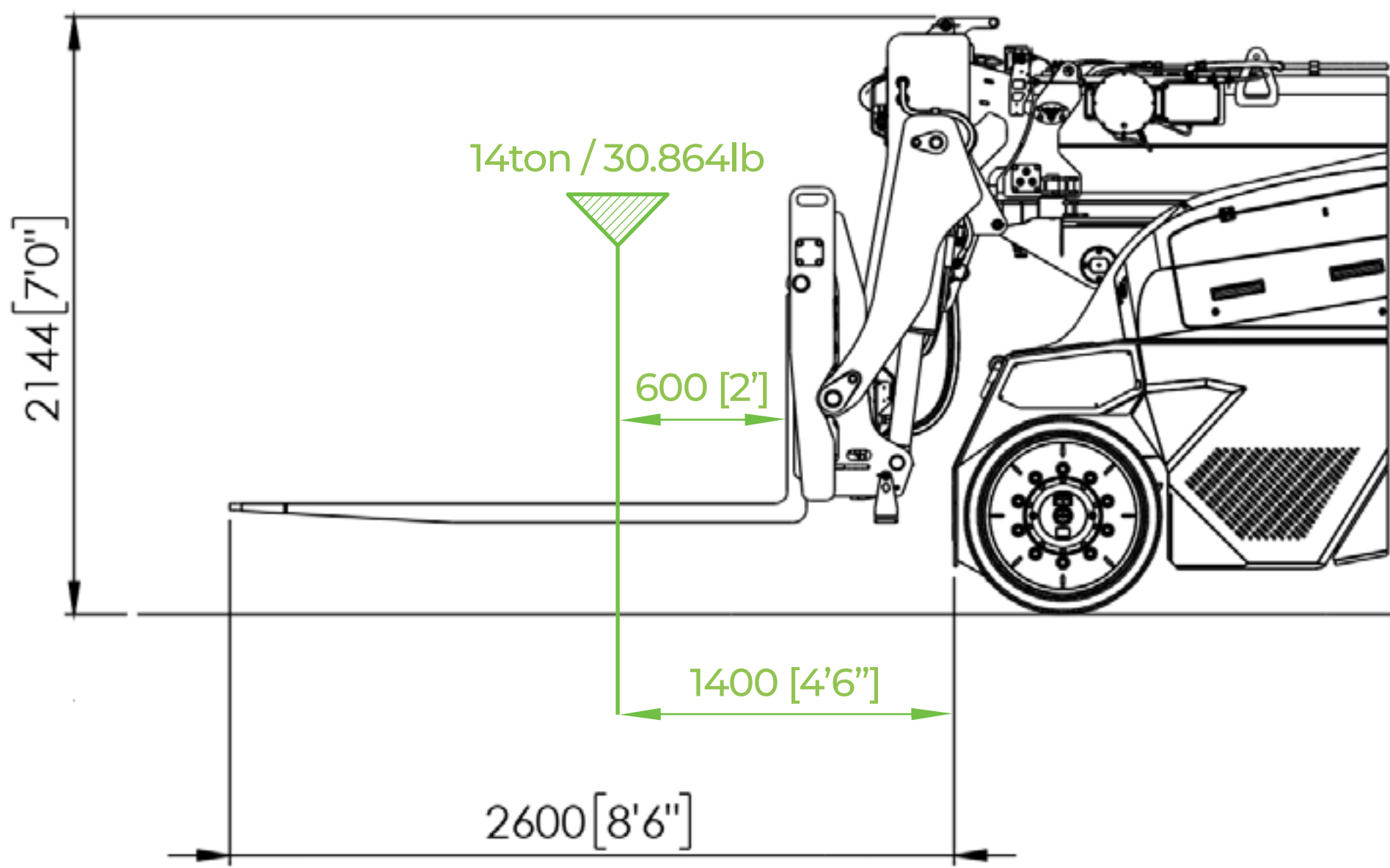

Fork on single-element boom



Ⓐ



Ⓑ



Ⓒ



Ⓐ

Long boom

Ⓑ

Short boom

Ⓒ

Single-element boom

JMG[®]

—
MC100.08





MC100.08 render



MC100.08
different booms same mobile cranes.



JMG Cranes S.p.A

Business headquarters:

Via Bergamo 142
26100 CREMONA (CR)
Italy

Production facility:

Via Zuccherificio 2
29010 SARMATO (PC)
Italy

+39 05238486

www.jmgcranes.com

info@jmgcranes.com