

JMG Cranes S.p.A.

Sales & Service Office

Via Bergamo, 142

26100 Cremona - Italy

t +39 0372 1786738

Production Plant

Via Zuccherificio 2

29010 Sarmato (PC) - Italy

t +39 0523 8486

e info@jmgcranes.com



Electric Pick & Carry Cranes



MC 32S (metric)
Max Capacity 3,200 Kg

www.jmgcranes.com



RADIO REMOTE CONTROLLED
FRONT-WHEELS DRIVE WITH COUNTER ROTATION
REMOVABLE COUNTERWEIGHT
SEQUENTIAL BOOM

Options :

- HYDRAULIC WINCH
- HYDRAULIC JIB
- NON-MARKING TIRES
- ATEX CONVERSIONS
- CUSTOMIZED PAINTING



Technical features

Max Capacity kg	3,200
Dimension mm	2430x980x1696

Front-wheels drive. 2 electric motors AC 3 kW 48V Insulation class H	LMI. Electronic safe load indicator and tilting moment limiter
Total Kg. 3,400 Removable counterweight Kg. 700	Automatic braking system on all wheels
48 V - 500 Ah 8 working hours	Fabricated from preformed and welded quality steel plate
Front nr. 2 superelastic 200/50-10" Rear nr. 2 superelastic 16x6-8"	+60°-15°
Rear Steering angle -90°/+90°	Motor driven pump 9 kW - 48 V AC, Insulation class H

Load charts

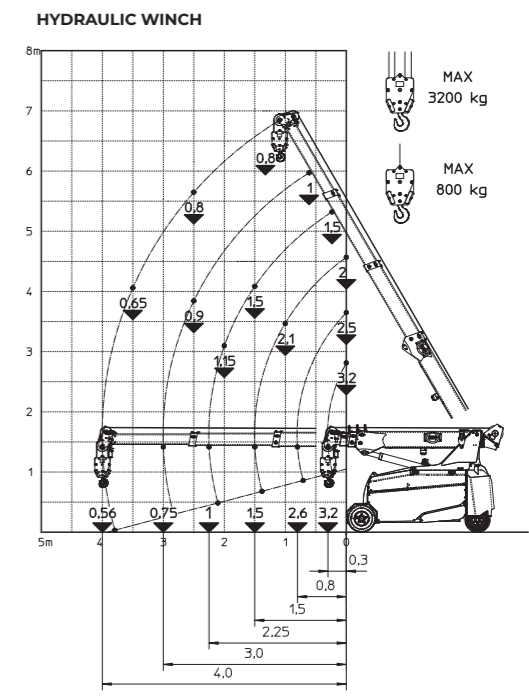
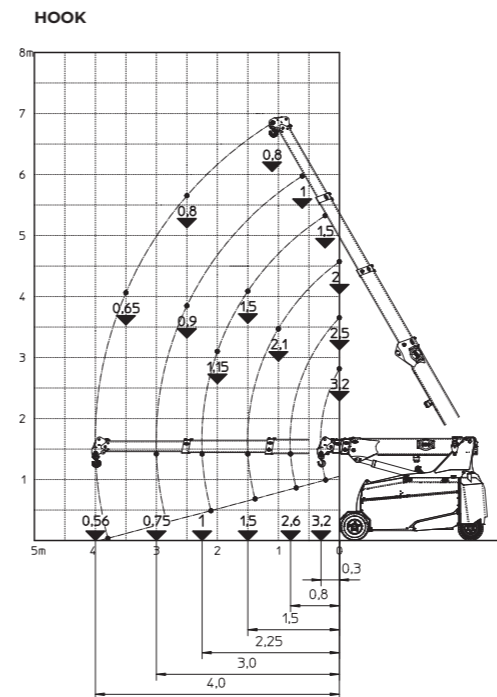

EU Standards CE

	UNI ISO 4301-2: A1
	2006/42 CE-2014/30 UE- 2000/14-4301 -1:A1 e and subsequent modifications
	EN 13000:2014 ANSI/ASME B30.5-2011 e and subsequent modifications

Dimensions

